

HBS507 Hybrid Servo Drive

20-50VDC, 8.0A Peak, Closed-loop, No Tuning

- Closed-loop, eliminates loss of synchronization
- Broader operating range – higher torque and higher speed
- Reduced motor heating and more efficient
- Smooth motion and super-low motor noise
- Do not need a high torque margin
- No Tuning and always stable
- Quick response, no delay and almost no settle time
- High torque at starting and low speed, high stiffness at standstill
- Offer servo-like performance at a much lower cost



Specifications

Electrical Specifications

Parameter	Min	Typical	Max	Unit
Input Voltage	20	36	50	VDC
Output Current	0	-	8.0(Peak)	A
Pulse Input Frequency	0	-	200	kHz
Logic Signal Current	7	10	16	mA
Isolation Resistance	500	-	-	MΩ

Operating Environment

Cooling	Natural Cooling or Forced cooling	
Operating Environment	Environment	Avoid dust, oil fog and corrosive gases
	Ambient Temperature	0°C — 50°C (32°F — 122°F)
	Humidity	40%RH — 90%RH
	Operating Temperature (Heat sink)	70°C (158°F) Max
	Vibration	5.9m/s ² Max
Storage Temperature	-20°C — 65°C (-4°F — 149°F)	
Weight	280g (10.0oz)	

Mechanical Specifications

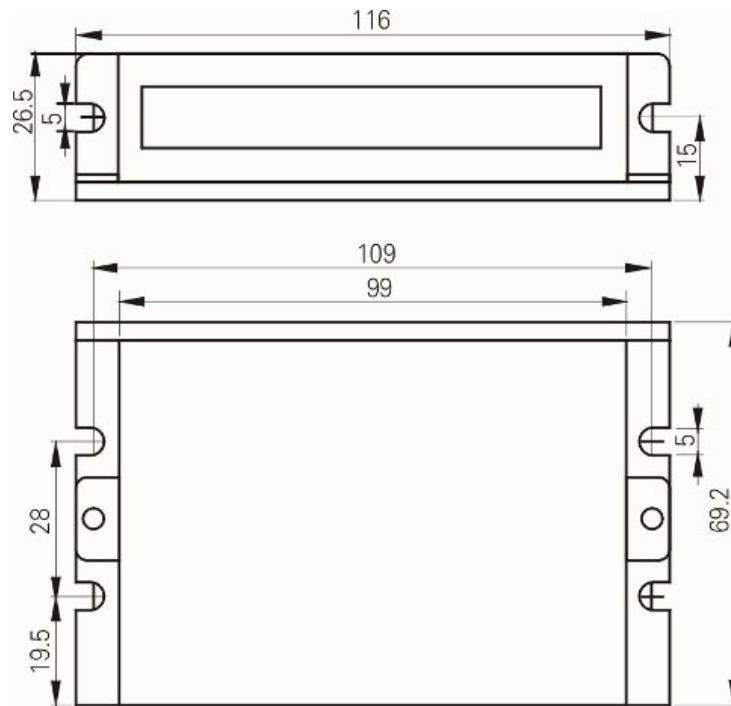

Protection Indications

Priority	Time(s) of Blink	Sequence wave of RED LED	Description
1 st	1		Over-current protection
2 nd	2		Over-voltage protection
3 rd	7		Position Following Error

Connectors and Pin Assignment

The HBS507 has three connectors, connector for control signals connections, connector for encoder feedback and connector for power and motor connections.

Control Signal Connector - Screw Terminal			
Pin	Pin Function	I/O	Description
1	PUL+	I	<u>Pulse signal</u> : In single pulse (pulse/direction) mode, this input represents pulse signal, each rising or falling edge active (software configurable, see the software operational manual for more details); In double pulse mode (software configurable), this input represents clockwise (CW) pulse, active both at high level and low level. 4-5V when PUL-HIGH, 0-0.5V when PUL-LOW. For reliable response, pulse width should be longer than 2.5 μ s. Series connect resistors for current-limiting when +12V or +24V used. The same as DIR and ENA signals.
2	PUL-	I	
3	DIR+	I	<u>Direction Signal</u> : In single-pulse mode, this signal has low/high voltage levels, representing two directions of motor rotation. In double-pulse mode (software configurable), this signal is counter-clock (CCW) pulse, active both at high level and low level. For reliable motion response, DIR signal should be ahead of PUL signal by 5 μ s at least. 4-5V when DIR-HIGH, 0-0.5V when DIR-LOW. Toggle DIP switch SW1 to reverse motion direction.
4	DIR-	I	
5	ENA+	I	<u>Enable Signal</u> : This signal is used for enabling/disabling the driver. In default, high level (NPN control signal) for enabling the driver and low level for disabling the driver. Usually left UNCONNECTED (ENABLED) . Please note that PNP and Differential control signals are on the contrary, namely low level for enabling. The active level of ENA signal is software configurable.
6	ENA-	I	
7	ALM+	O	<u>Alarm Signal</u> : OC output signal, active when one of the following protection is activated: over-voltage, over current, short circuit and position following error. This port can sink or source 20mA current at 24V. In default, the resistance between ALM+ and ALM- is low impedance in normal operation and become high when the HBS57 goes into error. The active level of alarm signal is software configurable. See the software operational manual for more details.
8	ALM-	O	

Encoder Feedback Connector – HDD15 Female			
Pin	Name	I/O	Description
1	EA+	I	Encoder channel A+ input
2	EB+	I	Encoder channel B+ input
3	EGD	GND	Signal ground
4	NC	I	Not Connected, Reserved for future use.
5	NC	I	Not Connected, Reserved for future use.
6	FG	-	Ground terminal for shielded
7	NC	I	Not Connected, Reserved for future use.
8	NC	I	Not Connected, Reserved for future use.
9	NC	I	Not Connected, Reserved for future use.
10	NC	-	Not Connected
11	EA-	I	Encoder channel A- input
12	EB-	I	Encoder channel B- input

Connectors and Pin Assignment (Continued)

Encoder Feedback Connector – HDD15 Female			
Pin	Name	I/O	Description
13	VCC	O	+5V @100 mA max.
14	NC	-	Not Connected
15	NC	-	Not Connected

Power and Motor Connector- Screw Terminal			
Pin	Name	I/O	Description
1	U	O	Motor Phase U
2	V	O	Motor Phase V
3	W	O	Motor Phase W
4	+VDC	I	Power Supply Input (Positive) 20-45VDC recommended, leaving room for voltage fluctuation and back-EMF.
5	GND	GND	Power Ground (Negative)

RS232 Communication Port

It is used to configure the peak current, microstep, active level, current loop parameters and anti-resonance parameters.

RS232 Communication Port			
Pin	Name	I/O	Description
1	NC	-	Not connected.
2	+5V	O	+5V power output.
3	TxD	O	RS232 transmit.
4	GND	GND	Ground.
5	RxD	I	RS232 receive.
6	NC	-	Not connected.

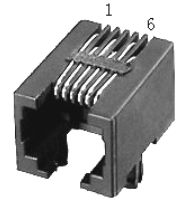

DIP Switch - Motor SEL

The SW1 can be used to change the motor direction. The SW2 is reserved for future use.

Current Control

The motor current will be adjusted automatically regarding to the load or the stator-rotor relationship. However, the user can also configure the current in the tuning software. The configurable parameters include close-loop current, holding current, encoder resolution, micro step and etc.

Typical Connections

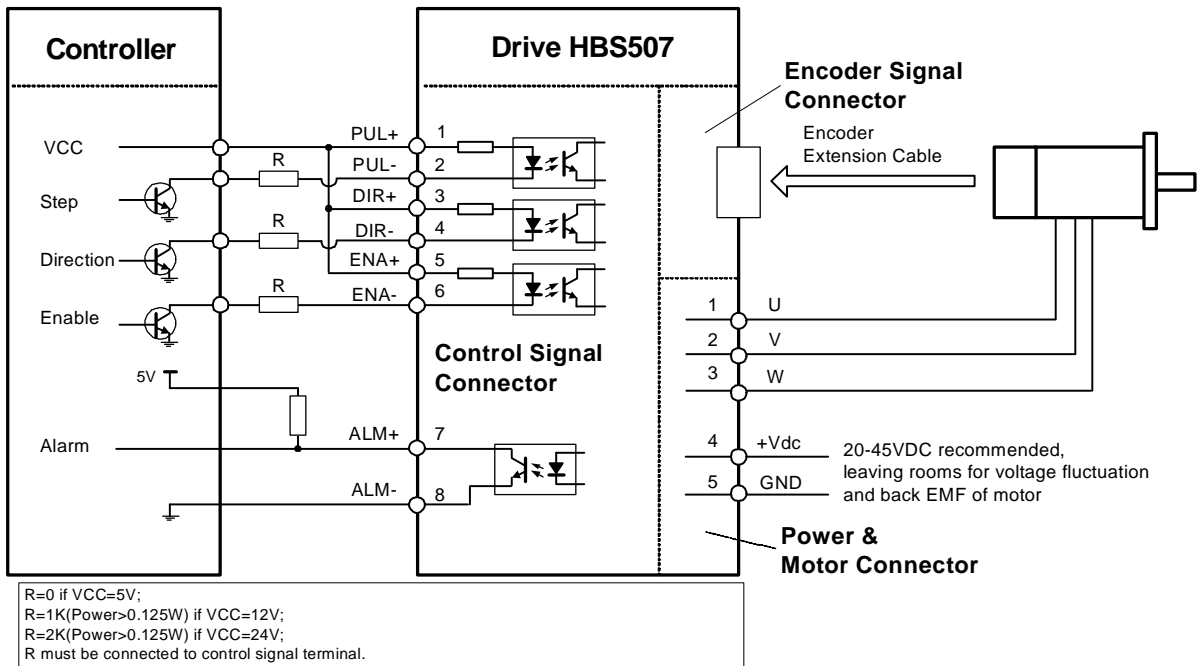

Connections to controller of sinking output

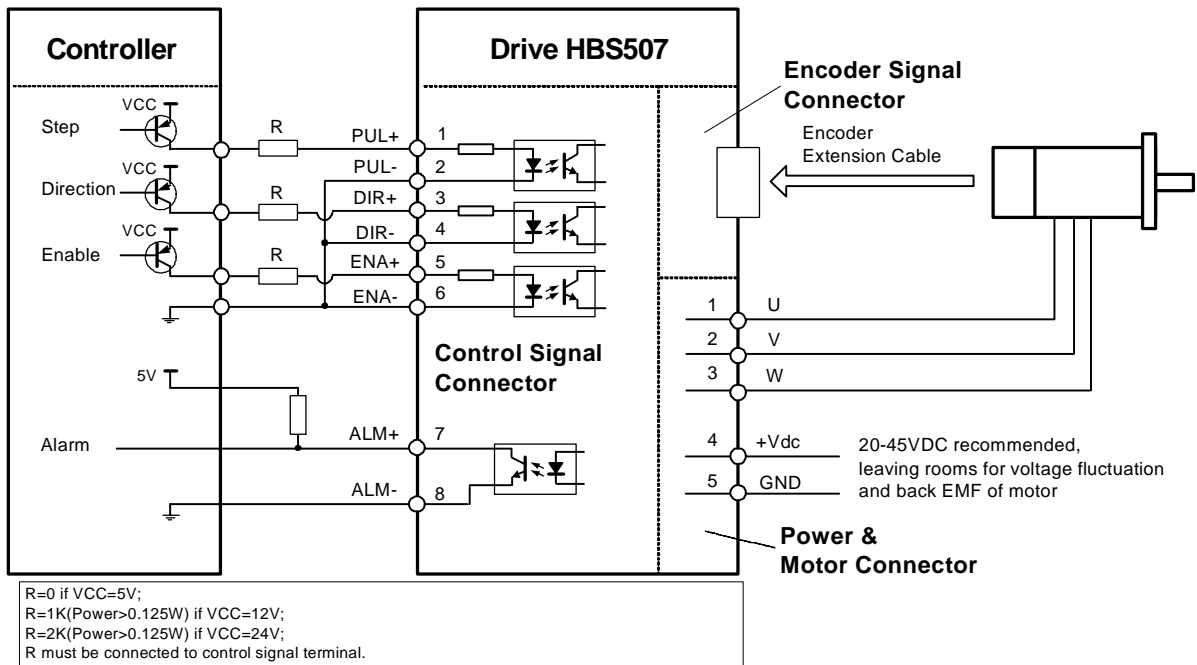

Connections to controller of sourcing output